

# MARINE TRANSMISSION

## DMT25AL

### ■ Standard Scope Of Supply

- Bell Housing (SAE 3, 4, 5)
- Rubber Block Coupling (11.5", 10", 7.5")
- Propeller Coupling, Reamer Bolt
- Manual Control Valve
- Oil Cooler
- Cable Bracket

### ■ Options

- Manual Trolling Valve
- Electronic Control Valve(12V,24V)
- Manual Trolling Valve + Electronic Control Valve(12V,24V)
- Mounting Bracket (Flat type, L type)

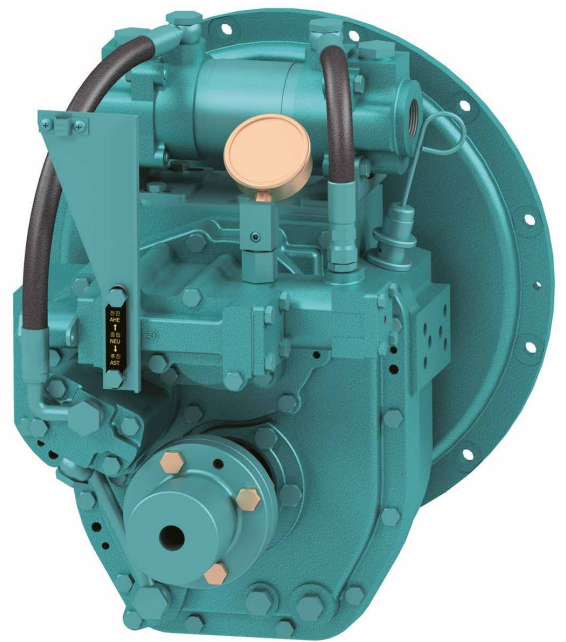

Model	Ratio	Max Input Torque		Capacity/RPM		Capacity/1800RPM		Max Input (RPM)	Bell Housing (SAE)	DRY WEIGHT (kg)
		(kgf.m)	(N.m)	kW	HP	kW	HP			
DMT25AL	1.64*, 2.07, 2.52, 2.96, 3.32	30	294	0.030	0.041	55	74	3500	3, 4, 5	68

\*Special Order Ratio

※ The dry weight is the weight that excludes bell housing, coupling (rubber block, dual stage, Centa flexible) and propeller coupling from the standard scope of supply.

※ The capacity for classification may differ from the capacity on the table, please contact our sales team.

※ SAE4 bell housing comes standard with A rubber block coupling.

## DMT25AL Dimensions

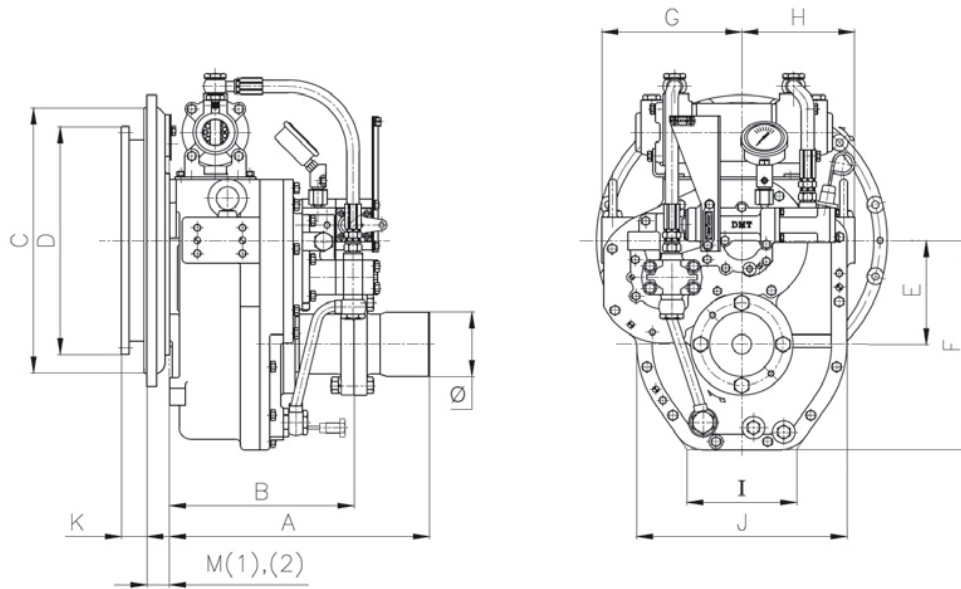

mm								
A	B	E	F	G	H	I	J	Ø
355	255	118	244	177	135	157	260	72

mm							
Bell Housing Standard	Driving Ring	C	D	M(1)	M(2)	K	
SAE#3	11.5"	409	352	34	-	39	
SAE#4	10"	361	314	30	-	53	
	7.5"	361	241	30	-	30	
SAE#5	7.5"	314	241	24	-	30	

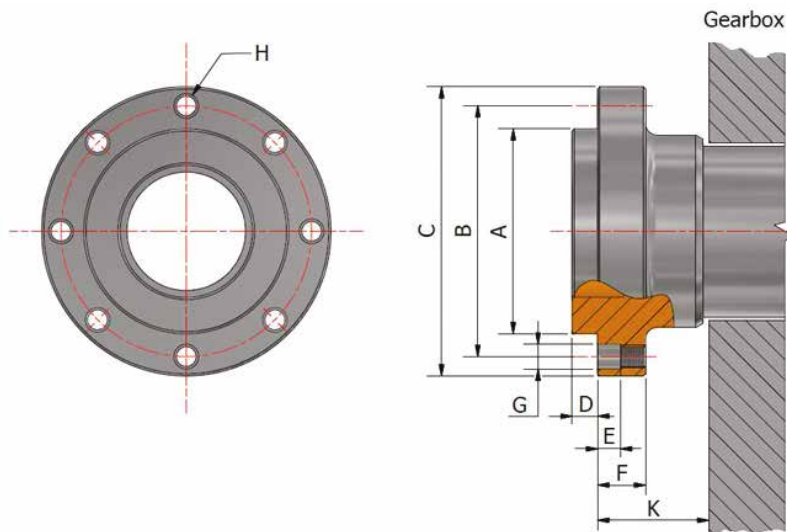

mm									
A	B	C	D	E	F	G	H	K	
Ø50	$\begin{matrix} 0 \\ -0.02 \end{matrix}$	Ø70	Ø88	5	8	16	Ø8.9	6-M8 P1.25	