

MARINE TRANSMISSION

DMT400H

■ Standard Scope Of Supply

- Bell Housing (SAE 0, 1)
- Centa Flexible Coupling (18", 14")
- Propeller Coupling, Reamer Bolt
- Manual Control Valve
- Oil Cooler
- Cable Bracket
- Live PTO

■ Options

- Manual Trolling Valve
- Electronic Control Valve(12V,24V)
- Manual Trolling Valve + Electronic Control Valve(12V,24V)
- Mounting Bracket (Flat type, L type)
- Parts for Live PTO(Pump Pad, Coupling)

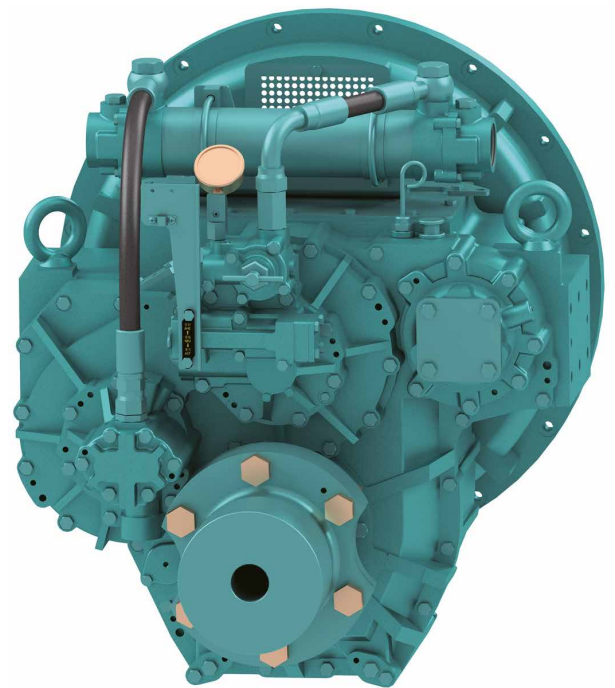

Model	Ratio	Max Input Torque		Capacity/RPM		Capacity/1800RPM		Max Input (RPM)	Bell Housing (SAE)	DRY WEIGHT (kg)
		(kgf.m)	(N.m)	kW	HP	kW	HP			
DMT400H	1.43*, 1.72*, 2.03	453	4443	0.464	0.623	836	1122	2300	0, 1	515
	2.46	403	3953	0.413	0.554	744	998			
	2.75	391	3835	0.401	0.537	722	969			

*Special Order Ratio

※ The dry weight is the weight that excludes bell housing, coupling (rubber block, dual stage, Centa flexible) and propeller coupling from the standard scope of supply.

※ The capacity for classification may differ from the capacity on the table, please contact our sales team.

DMT400H Dimensions

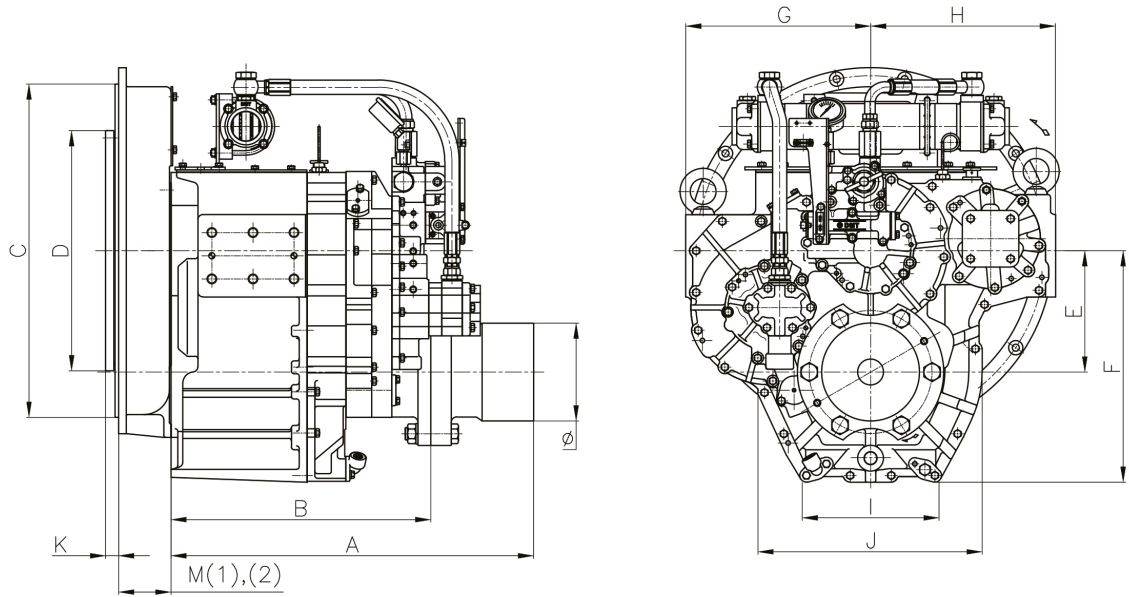

mm

A	B	E	F	G	H	I	J	Ø
705	505	235	450	360	360	266	436	190

mm

Bell Housing Standard	Driving Ring	C	D	M(1)	M(2)	K
SAE#0	18"	647	571	-	130	15
SAE#0	14"	647	466	-	130	25
SAE#1	14"	511	466	-	122	25

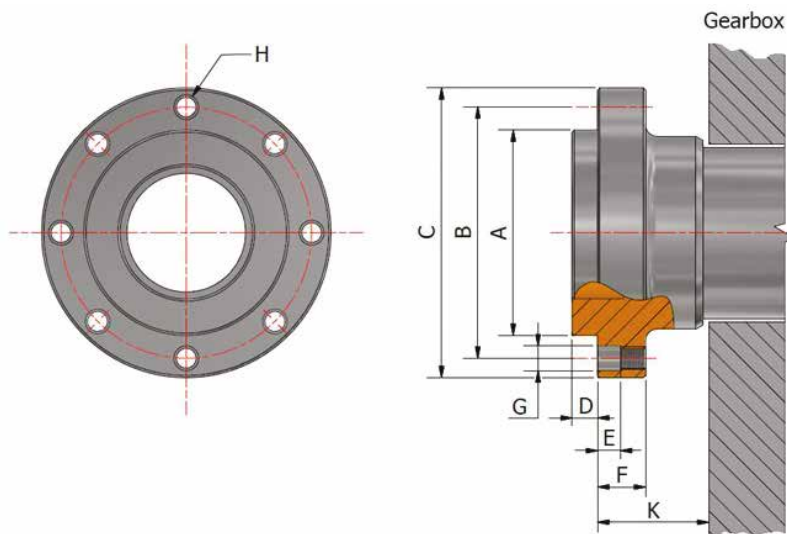

mm

A	B	C	D	E	F	G	H	K	
Ø129	$\begin{matrix} 0 \\ -0.02 \end{matrix}$	Ø155	Ø177	7	11	25	Ø16	8-M14 P1.5	35.7