

HYUNDAI SP344CB



50/60Hz
MULTI
FREQUENCY
GENERATOR



GENERATOR



Fuel
Optimized

Description

- HD Hyundai Infracore's compact electronic engines SP344 series is one of the key products which is produced in HDI's China factory and has the same hardware of DM03 produced in Korea.



Features

[Performance & Fuel Economy Improvement]

- Bosch 1,800bar common rail system
- Ultra low fuel consumption
- Air management improved through optimization of valve timing & turbocharger matching

[Convenience & TCO]

- Maintenance free for valve clearance
- Auto tensioner belt drive system
- Oil level sensor option for 1,000hrs exchange interval

Power

	50 Hz / 1500 rpm									60 Hz / 1800 rpm								
	Standby Power			Prime Power			Continuous Power			Standby Power			Prime Power			Continuous Power		
	kWm	kWe	kVA	kWm	kWe	kVA	kWm	kWe	kVA	kWm	kWe	kVA	kWm	kWe	kVA	kWm	kWe	kVA
SP344CB	61	51	64	56	46	58				74	61	76	67	55	69			

Generator efficiency (typical) :

kWm= kiloWatt mechanical, net with fan*; kWe= kiloWatt electrical = kWm x Generator eff.; kVA= kiloVoltAmpere calculations based on a 0.8 power factor = kWe/0.8

1kW= 1 hp x 1.36; 1hp= 1kW x 0.7355

*Based upon technical data



General Data

Type	Diesel, water cooled, Turbo charged & intercooled
Bore	98mm
Stroke	113mm
Displacement liter	3.4
Cylinders and Arrangement	Cast iron, 4 cylinder, In-line Type
Battery charging alternator	12V x 110A
Starting voltage	12V
Fuel System	Mechanical Injection Pump
Fuel Filter	Full flow, spin-on type (Pre-filter with water in fuel sensor)
Lube oil filter type(s)	Full flow, spin-on type
Lube oil capacity (l)	Max. 12.6 liters , Min. 6liters
Flywheel dimensions	SAE J620 11.5"

Coolpac Data

Cooling method	Coolant forced circulation by centrifugal pump on engine	
Cooling ratio	50% ethylene glycol; 50% water	
Water capacity (L)	with radiator	14.2liters
	without radiator	4liters
Fan power (kWm)	1.8kW(50Hz), 3.5kW(60Hz)	
Cooling system air flow(m ³ /s)	1.98	

Fuel Consumption

Fuel Consumption 1500 (50Hz)

%	kWm	BHP	Liters/hr	USgal/hr
Standby Power				
100	61.4	82.3	15.1	3.99
Prime Power				
100	55.6	74.6	13.8	3.65
75	41.7	55.9	10.5	2.77
50	27.8	37.3	7.4	1.95
25	13.9	18.6	4.4	1.16
Continuous Power				
100				

Fuel Consumption 1800 (60Hz)

%	kWm	BHP	Liters/hr	USgal/hr
Standby Power				
100	73.5	98.6	18.1	4.78
Prime Power				
100	66.6	89.3	16.6	4.39
75	50.0	67.0	13.0	3.43
50	33.3	44.7	9.2	2.43
25	16.7	22.3	5.7	1.51
Continuous Power				
100				



Dimensions

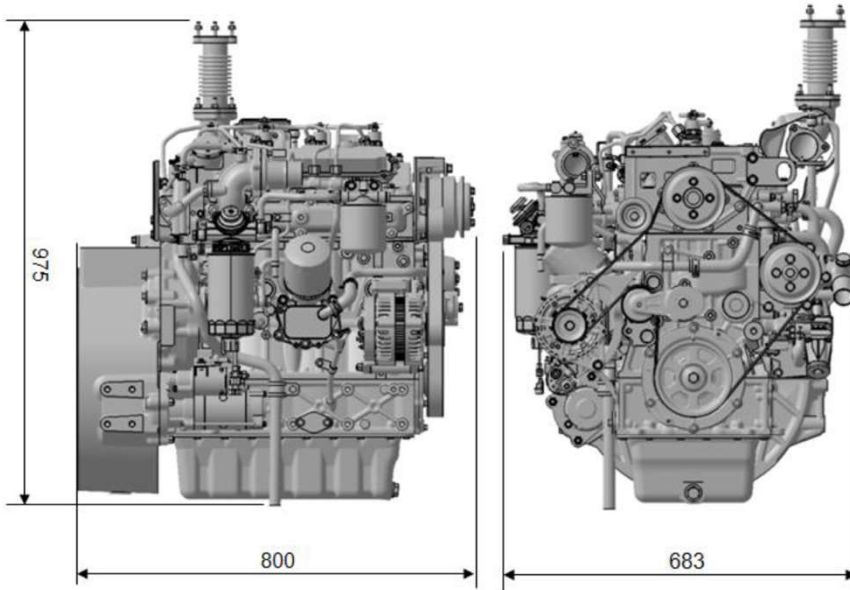

Weights and Dimensions

Length mm	Width mm	Height mm	Weight (dry) kg
800	683	975	365

Power Rating Guide

The power ratings of Emergency Standby and Prime are in accordance with ISO 8528. Fuel Stop power in accordance with ISO 3046.

Electric power (kWe) must be considered cooling fan loss, alternator efficiency, altitude derating and ambient temperature.

ESP(STANDBY POWER) is applicable for supplying emergency power for the duration of the utility power outage.

No overload capability is available for this rating.

A standby rated engine should be sized for a maximum of an 70% average load factor and 200 hours of operation per year. This includes less than 25 hours per year at the Standby Power rating.

PRP(PRIME POWER) is available for an unlimited number of hours per year in variable load application. Variable load should not exceed a 70% average of the Prime Power rating during any operating period of 24 hours.

The Total operating time at 100% Prime Power shall not exceed 500 hours per year.

A 10% overload capability is available for a period of 1 hour within a 12 hour period of operation.

Total operating time at the 10% overload power shall not exceed 25 hours per year.

COP(CONTINUOUS POWER) is defined as being the maximum power which the generating set is capable of delivering continuously whilst supplying a constant electrical load when operated for an unlimited number of hours per year under the agreed operating conditions with the maintenance intervals and procedures being carried out as prescribed by the manufacturer.

※ Specifications are subject to change without prior notice.

